

PART NO. CB-4488-2M

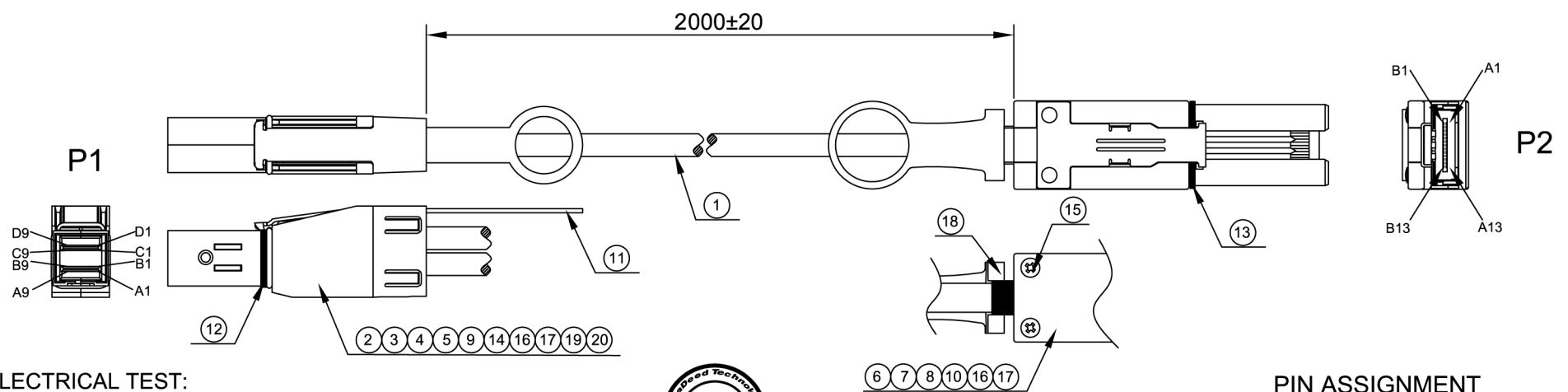

ELECTRICAL TEST:
 1.OPEN / SHORT 100% TEST.
 2.CONTACT RESISTANCE : 1Ω(MAX).
 3. INSULATION RESISTANCE : 20MΩ (MIN).
 4.HI-POT : DC 300V /10MS.

PIN ASSIGNMENT

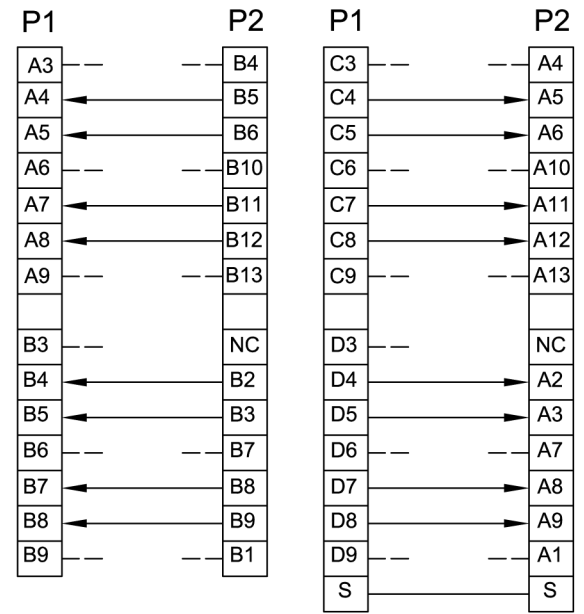

20	4-21-0062-000001	capacitance	1	PCS
19	4-21-0061-000001	IC	1	PCS
18	4-20-0063-001001	ACETATE TAPE BLACK W=10mm	100	mm
17	4-20-0002-051051	CONDUCTIVE COPPER FOIL W:5.0mm	100+50	mm
16	4-15-0001-200201	Heat shrink tube OD:0.6mm BLACK	3.0*16	mm
15	4-13-0032-M26551	SCREW M2*0.65 NICKEL PLATED	2	PCS
14	4-12-0065-U30400	EXT.HD MINI SAS LATCH	1	PCS
13	4-12-0016-000051	EXT.MINI SAS 26P CONDUCTIVE FOAM	1	PCS
12	4-12-0068-013013	EXT.HD MINI SAS CONDUCTIVE FOAM	1	PCS
11	3-07-0001-006651	PA66	3	g
10	3-02-0002-086701	TRL-THERMELT-867	8	g
9	3-02-0001-532151	PE	5	g
8	2-70-0005-011501	MINI SAS 26P ZINE ALLOY BOTTOM SHELL NICKEL PLATED	1	PCS
7	2-70-0002-011501	MINI SAS 26P ZINE ALLOY UP SHELL NICKEL PLATED	1	PCS
6	2-70-0004-011501	EXT.MINI SAS 26P PCB FR-4 1.0mm 5u"	1	PCS
5	2-70-0020-011501	EXT.HD MINI SAS ZINE ALLOY SHELL NICKEL PLATED (RIGHT)	1	PCS
4	2-70-0021-011501	EXT.HD MINI SAS ZINE ALLOY SHELL NICKEL PLATED (LEFT)	1	PCS
3	2-70-0023-011501	EXT.HD MINI SAS PCB C/D	1	PCS
2	2-70-0022-011501	EXT.HD MINI SAS PCB A/B	1	PCS
1	1-70-0009-200201	UL20276 (2C*28#+D+AL+ML)*4C+ ML+AL+B+P OD:5.5 BLACK	1065.0*2	mm
NO.	PART NO.	DESCRIPTION	Q'TY	UNIT

CineRAID
 Advanced Storage for Digital Cinema

EXT. HD MINI SAS TO EXT MINI SAS 26P CABLE 2M

APPROVALS DRAWN	DATE	SIZE SCALE : C XX : XX ID NO.	DRAWING NO. 6703139	REV. A0
CHECKED	DATE			
APPROVAL	DATE			

DIMENSION ARE MILLIMETERS TOLERANCES ARE :
DECIMALS ANGLES
X ± 0.30 ± 3°
.XX ± 0.20
DO NOT SCALE DRAWING

SHEET 1 OF 1